

LORI®

Sweet Escape Luxury SUV™

age
3+

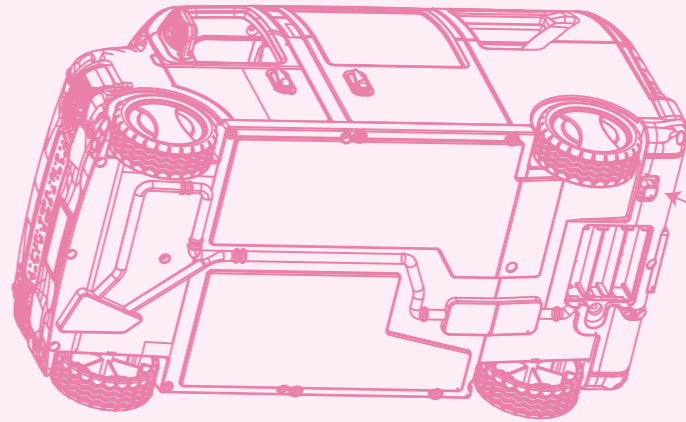
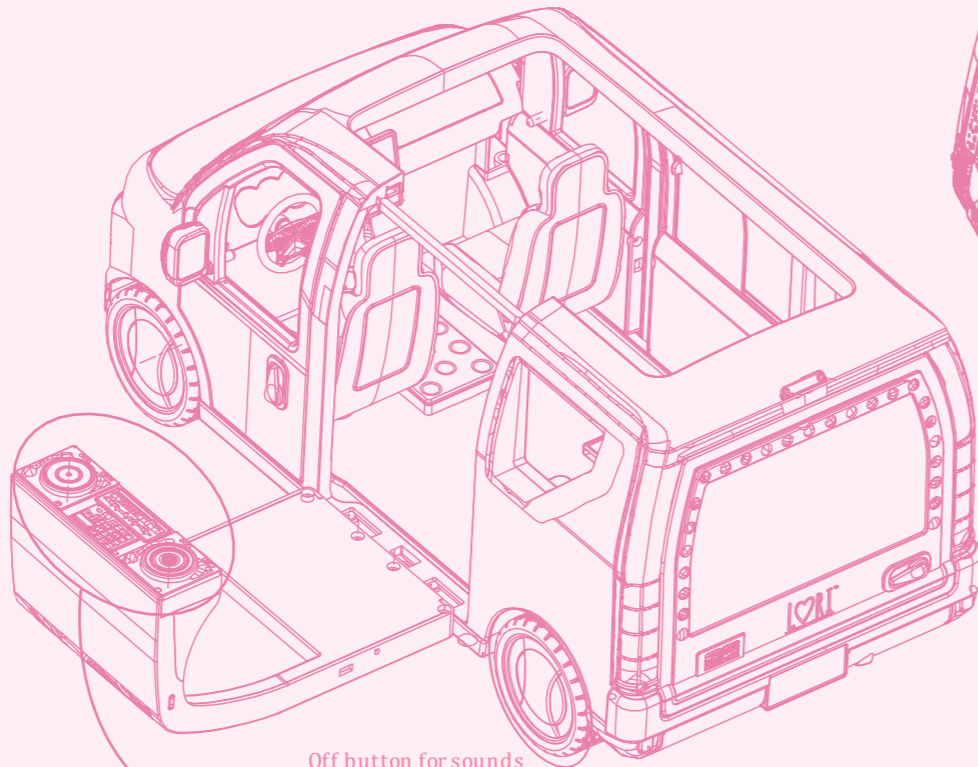

ON/OFF/TRY ME
BUTTON

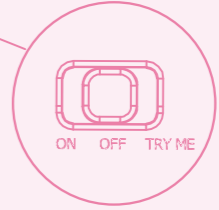

Battery Replacement

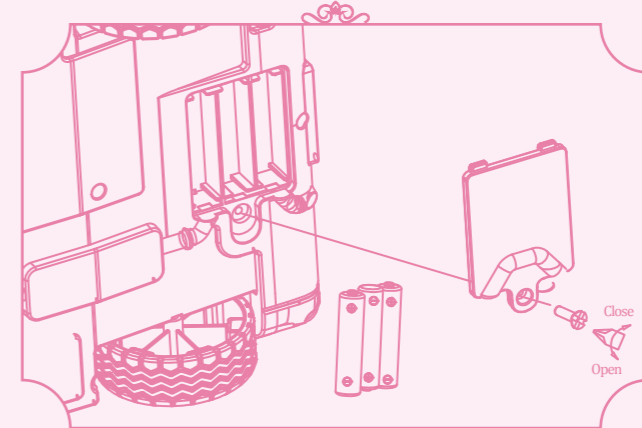

1. Open the battery cover with Phillip type screw driver (not included) and install 3 x AA (1.5V) batteries.
2. Must follow the correct battery polarity. Close the battery cover with a screwdriver.

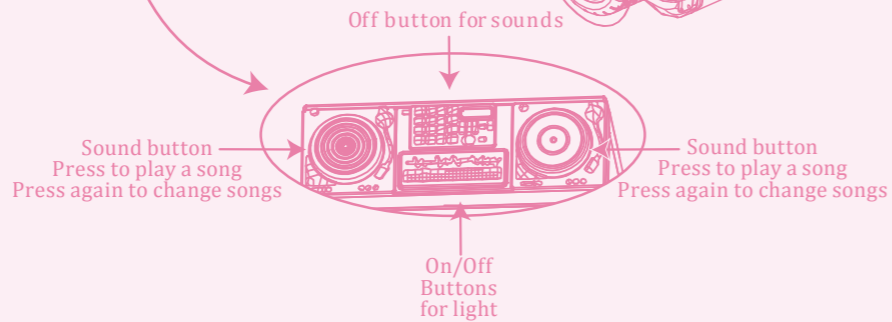

L037055

WARNING:
CHOKING HAZARD - Small parts.
Not for children under 3 years.

Attention: Please
keep all packaging
materials and screws
away from children.
CAN ICES-3 (B)/NMB-3(B)

CAUTION:
Uses 3 x AA (1.5V) size batteries - Included
Do not mix old and new batteries. Do not mix alkaline, standard
(carbon-zinc), or rechargeable batteries.
Do not dispose of this product in fire. Batteries inside product
may explode or leak.



This device complies with Part 15 of the FCC Rules. Operation is subject to the following two conditions: (1) this device may not cause harmful interference, and (2) this device must accept any interference received, including interference that may cause undesired operation. Caution: changes or modifications not expressly approved by the party responsible for compliance could void the user's authority to operate the equipment. NOTE: This equipment has been tested and found to comply with the limits for a Class B digital device, pursuant to Part 15 of the FCC Rules. These limits are designed to provide reasonable protection against harmful interference in a residential installation. This equipment generates, uses and can radiate radio frequency energy and, if not installed and used in accordance with the instructions, may cause harmful interference to radio communications. However, there is no guarantee that interference will not occur in a particular installation. If this equipment does cause harmful interference to radio or television reception, which can be determined by turning the equipment off and on, the user is encouraged to try to correct the interference by one or more of the following measures: • Reorient or relocate the receiving antenna. • Increase the separation between the equipment and receiver. • Connect the equipment into an outlet on a circuit different from that to which the receiver is connected. • Consult the dealer or an experienced radio/TV technician for help.

A4 SIZE